

## Product image

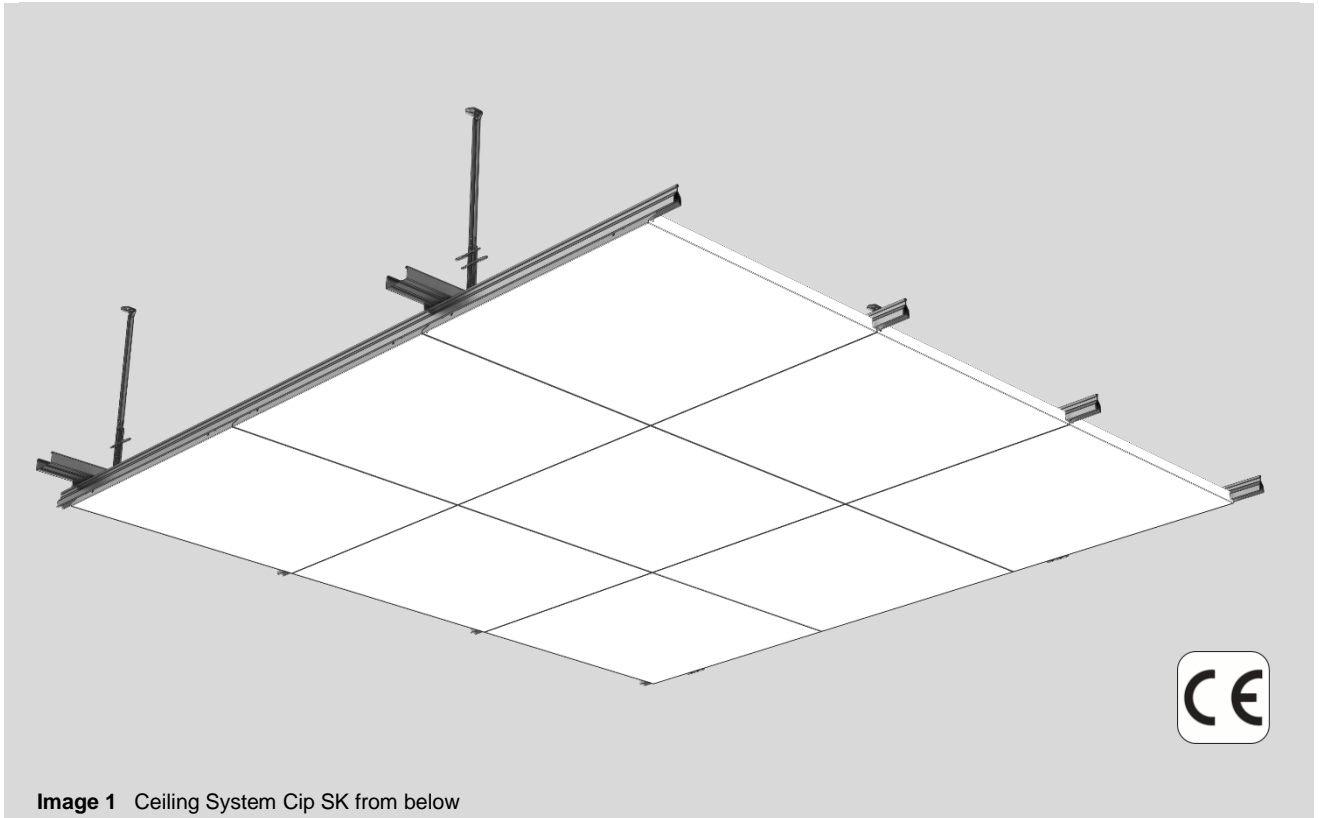

Image 1 Ceiling System Clip SK from below

## Fields of application

- Pharmaceutical production, medical engineering
- Microelectronics and semiconductor industries
- Microsystems technologies, precision engineering
- Surface treatment technologies
- Operating theatres



- Easy to clean
- Good resistance against numerous detergents and disinfectants from the VAH-List (Verbund für angewandte Hygiene)



GMP suitability

## Certification/Standards

Ceiling system according to EN 13964.

Quality standard according to the technical standards of TAIM  
(Verband Industrieller Metalldeckenhersteller TAIM e.V.).

### Technical Data

Standard grid <sup>1)</sup>	600 x 600 mm
	625 x 625 mm
Maximum suspension distance	1200 x 1200 mm
Maximum suspension height	from 80 mm
System weight	approx. 10 kg/m <sup>2</sup> (without installations)
System height	approx. 80 mm
Fire protection classification	F0
Joint width <sup>2)</sup>	approx. 1 mm
Serviceability	completely removeable

<sup>1)</sup> Special dimensions on request

<sup>2)</sup> Joints optionally sealed according to the cleanroom requirements

### Substructure

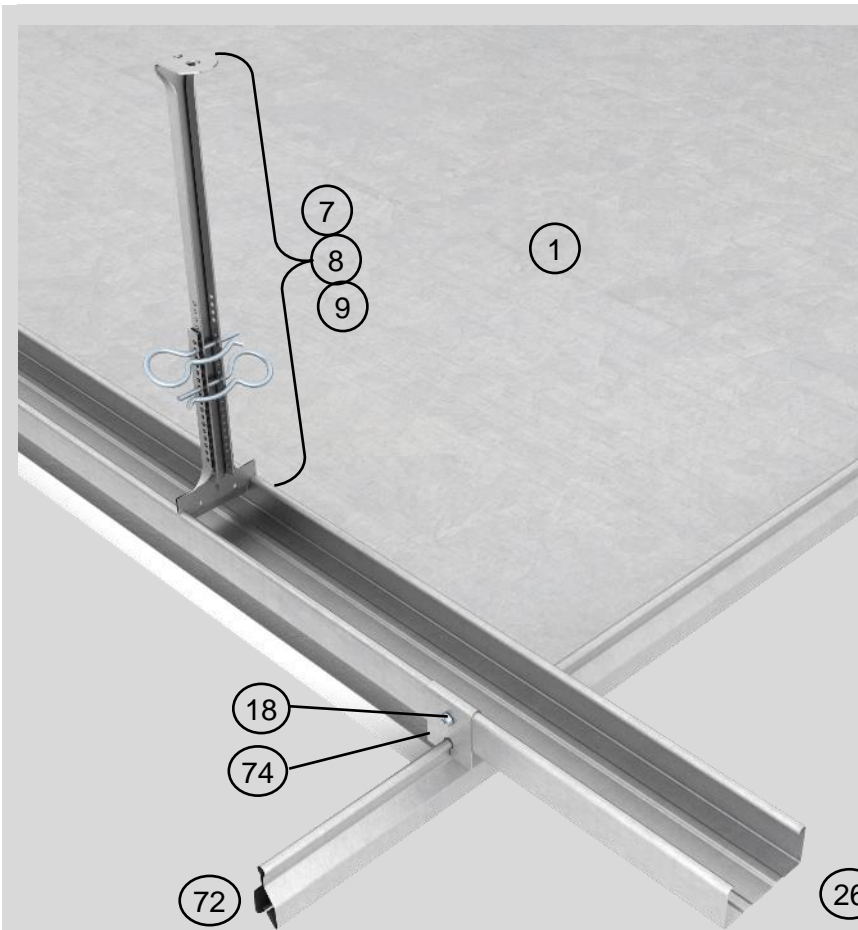

#### Components:

- 1 = Clip cassette SK
- 18 = Drywall screw
- 26 = Suspension channel
- 72 = Clip-in profile
- 74 = Cross connector
- 7/8/9 = Vernier suspension

**Image 2** Clip SK Substructure

### General description

Cassette ceiling with powder-coated ceiling cassettes, manufactured in accordance with European standards and TAIM standard. The Clip SK ceiling system is characterised by high tightness as well as easy cleanability and disinfectability. GMP- and DIN EN ISO 14644-compliant design. The surface is smooth, even, allows flush mounting and contains no outgassing or particle-emitting materials. The tightness of the ceiling joints is achieved by a sealing suitable for clean rooms.

Qualification certificates and proof of air permeability on request.

#### ① Clip cassette type SK

<b>Size and Material</b>	Flush ceiling panel, made of galvanised steel.
<b>Edging of ceiling panel</b>	all sided L-folding
<b>Surface</b>	<ul style="list-style-type: none"> <li>• Powder coated according to RAL or other common colour systems</li> <li>• Anodised Aluminium</li> </ul>
<b>Gloss level</b>	approx. 20E (RAL 9010)
<b>Serviceability</b>	swing-down option or completely removeable

#### ⑱ Drywall screw

Drywall screw for connecting the cross-connector clamping profile to the suspension channel.

#### ⑳ Suspension channel

CD profile, galvanised sheet steel, suspended from a concrete ceiling or a steel construction.

#### ㉓ Clip-In profile

Clamping profile made of galvanized sheet steel to fix the ceiling cassettes with clamping knobs.

#### ㉕ Cross connector

Galvanised sheet steel for connecting the clamping profile to the suspension channel.

#### ㉗/㉘/㉙ Vernier suspension

Consisting of:

Vernier-Hanger lower section
Vernier-safety pin (2 pcs./suspension)
Vernier-Hanger upper section

#### Wall connection angle (no image)

Wall angle to connect the ceiling system to partitions, concrete walls, etc. Different designs available. Made of galvanised steel, optionally made of Aluminum.

---

## Additional equipment / installations

---

**Light fixtures**

Installation of recessed lights and luminaires from Lindner or from other manufacturers <sup>1)</sup> is possible.

**Air conditioning components**

The ceiling system is compatible with Filter Fan Units / air supply exhausts / air grilles and other air conditioning components.

**Other**

Sprinklers, smoke detectors or media ducts can be set through the ceiling panels

1) Situation-related clarification necessary

No additional loads may be applied to the ceiling system!

---

## Manufacturing tolerances

---

Lindner metal ceilings are produced in accordance with the requirements of EN 13964 as well as the TAIM technical regulations (Verband Industrieller Metalldeckenhersteller TAIM e.V. - [www.taim.info](http://www.taim.info)).

This data sheet refers to the standard version of the above-mentioned ceiling system. Project-specific remarks and adaptations can be found in addition to the tender documents.

---

## Installation and use

---

The assembly and use shall be in accordance with the manufacturer's guidelines and the technical regulations of the TAIM.